



# Type 439

Safety Relief Valves  
– spring loaded

Metric Units



## Facts

**LESER**

[The-Safety-Valve.com](http://The-Safety-Valve.com)

## Available designs

Type 439

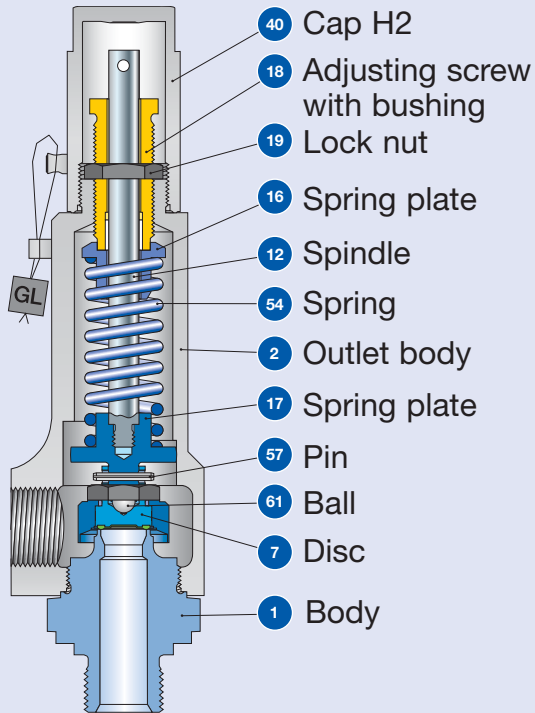

**Conventional design**  
Threaded connection

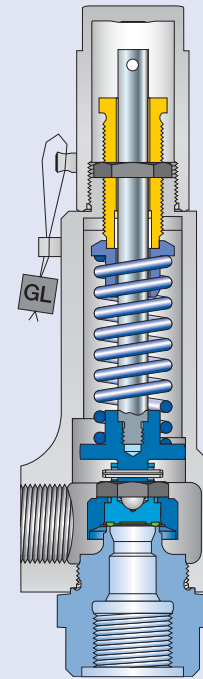

**Conventional design**  
Threaded connection

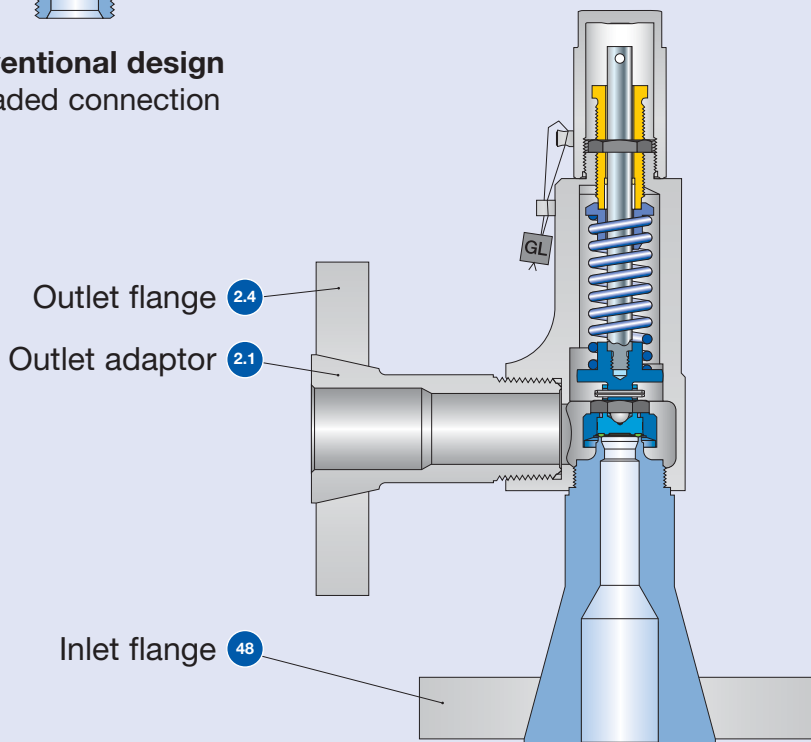

**Conventional design**  
Flange connection

## Available designs – materials

Materials			Type 4393	Type 4394
Item	Component	Remarks	Type 4393	Type 4394
1	Base / Inlet body	Threaded connection	1.4104 <sup>1)</sup> , 1.4404 SA 479 430 <sup>1)</sup> , SA 479 316L	1.4404 SA 479 316L
		Flange connection	1.4404 SA 479 316L	1.4404 SA 479 316L
2	Outlet body		1.4104 SA 479 430	1.4404 SA 479 316L
2.1	Outlet adaptor	Flange connection	1.4404 316L	1.4404 316L
2.4	Outlet flange	Flange connection	1.4404 316L	1.4404 316L
7	Vulcanized soft seal disc		1.4404 SA 479 316L	1.4404 SA 479 316L
7.1	Disc with vulcanized soft seal	“N”	NBR Nitrile-Butadiene	NBR Nitrile-Butadiene
		“K”	CR Chloroprene	CR Chloroprene
		“D”	EPDM Ethylen-Propylene-Diene	EPDM Ethylen-Propylene-Diene
		“L”	FKM Fluorocarbon	FKM Fluorocarbon
		“C”	FFKM Perfluor	FFKM Perfluor
12	Spindle <sup>2)</sup>		1.4021 420	1.4571 316Ti
16/17	Spring plate <sup>2)</sup>		1.4104 Chrome steel	1.4404 316L
18	Adjusting screw with bushing		1.4104 / PTFE Chrome steel / PTFE	1.4404 / PTFE 316L / PTFE
19	Lock nut		1.0718 Steel	1.4404 316L
40	Cap H2		1.0718 Steel	1.4404 316L
48	Inlet flange	Flange connection	1.4404 316L	1.4404 316L
54	Spring		1.4310 Stainless steel	1.4310 Stainless steel
57	Pin		1.4310 Stainless steel	1.4310 Stainless steel
61	Ball		1.3541 Hardened stainless steel	1.4401 316

<sup>1)</sup> Only for male thread DIN ISO 228-1 G<sup>3</sup>/<sub>8</sub>, G<sup>1</sup>/<sub>2</sub>, G<sup>3</sup>/<sub>4</sub> (Option codes V49, V54, V55).

<sup>2)</sup> The items 12 and 17 are combined to one unit.

**Please notice:**

- Modifications reserved by LESER.
- LESER can upgrade materials without notice.
- Every part can be replaced by other material acc. to customer specification.

## How to order – Article numbers

### Article numbers

Actual Orifice diameter $d_0$ [mm]	10
Actual Orifice area $A_0$ [mm <sup>2</sup> ]	78.5
Actual Orifice diameter $d_0$ [inch]	0.394
Actual Orifice area $A_0$ [inch <sup>2</sup> ]	0.122
<b>Soft seal material</b>	NBR "N" J30
	CR "K" J21
	EPDM "D" J22
	FKM "L" J23
	FFKM "C" J20

### Base / Inlet body material: 1.4104 (430)

<b>H2</b>	Art.-No. <b>4393.</b>	<b>2882</b>
<b>H3</b>	Art.-No. <b>4393.</b> $p_{max} = 10 \text{ bar}_g$	<b>2883</b>
<b>H4</b>	Art.-No. <b>4393.</b>	<b>2884</b>
p [bar <sub>g</sub> ]	S/G/L	<b>0.1 – 16</b>
p [psig]	S/G/L	<b>1.5 – 232</b>

### Base / Inlet body material: 1.4404 (316L)

<b>H2</b>	Art.-No. <b>4394.</b>	<b>2892</b>
<b>H4</b>	Art.-No. <b>4394.</b>	<b>2894</b>
p [bar <sub>g</sub> ]	S/G/L	<b>0.1 – 16</b>
p [psig]	S/G/L	<b>1.5 – 232</b>

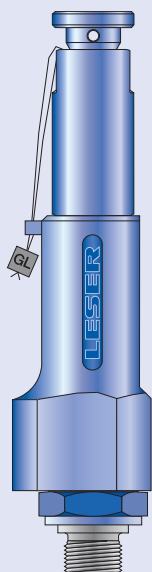

**Type 439 Male**  
Outlet body 1/2"  
Pull button H3  
Conventional design

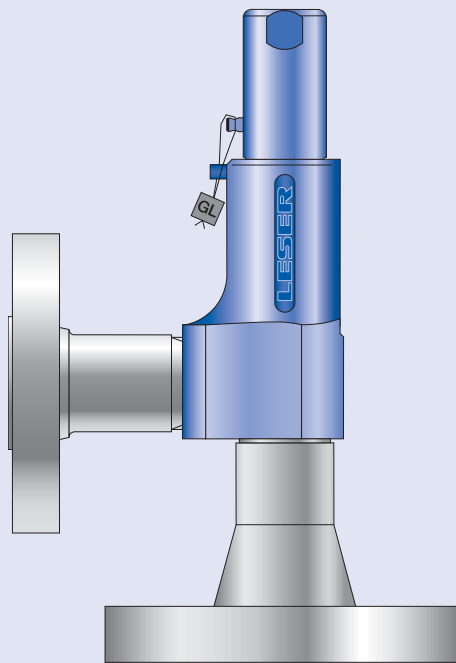

**Type 439 Flanged connection**  
Outlet body 1"  
Cap H2  
Conventional design

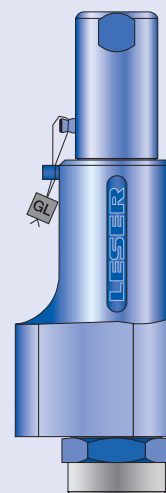

**Type 439 Female**  
Outlet body 1"  
Cap H2  
Conventional design

## Pressure temperature ratings

Metric Units					
Actual Orifice diameter $d_0$ [mm]		10			
Actual Orifice Area $A_0$ [mm <sup>2</sup> ]		78.5			
Body material: 1.4104 (430)					
Base / Inlet Body	Connection size	3/8"	1/2"	3/4"	1"
	Pressure rating	PN 320			
Outlet body	Pressure rating	PN 160			
Minimum set pressure	p [bar <sub>g</sub> ] S/G/L	0.1			
Maximum set pressure	p [bar <sub>g</sub> ] S/G/L	16			
Temperature acc. to DIN EN	min. [°C]	-10			
	max. [°C]	+150			
Temperature acc. to ASME	min. [°C]	-29			
	max. [°C]	+150			
Body material: 1.4404 (316L)					
Base / Inlet Body	Connection size	3/8"	1/2"	3/4"	1"
	Pressure rating	PN 320			
Outlet body	Pressure rating	PN 160			
Minimum set pressure	p [bar <sub>g</sub> ] S/G/L	0.1			
Maximum set pressure	p [bar <sub>g</sub> ] S/G/L	16			
Temperature acc. to DIN EN	min. [°C]	-45			
	max. [°C]	+150			
Temperature acc. to ASME	min. [°C]	-45			
	max. [°C]	+150			
US Units					
Actual Orifice diameter $d_0$ [inch]		0.394			
Actual Orifice area $A_0$ [inch <sup>2</sup> ]		0.122			
Body material: 1.4104 (430)					
Base / Inlet Body	Connection size	3/8"	1/2"	3/4"	1"
	Minimum set pressure	p [psig] S/G/L	1.5		
Maximum set pressure	p [psig] S/G/L	232			
Temperature acc. to DIN EN	min [°F]	+14			
	max [°F]	+302			
Temperature acc. to ASME	min [°F]	-20			
	max [°F]	+302			
Body material: 1.4404 (316L)					
Base / Inlet Body	Connection size	3/8"	1/2"	3/4"	1"
	Minimum set pressure	p [psig] S/G/L	1.5		
Maximum set pressure	p [psig] S/G/L	232			
Temperature acc. to DIN EN	min [°F]	-49			
	max [°F]	+302			
Temperature acc. to ASME	min [°F]	-49			
	max [°F]	+302			

## Dimensions and weights – Metric Units

### Threaded connections

Size Outlet body		1/2"	3/4"	1"
Actual Orifice diameter $d_0$ [mm]		10	10	10
Actual Orifice area $A_0$ [mm <sup>2</sup> ]		78.5	78.5	78.5
Weight [kg]		1.2	1.6	1.6
Required installation diameter [mm]		65	80	80

### Inlet thread "Female"

Size outlet body		1/2"	3/4"	1"	
<b>Center to face [mm]</b>					
<b>DIN ISO 228-1</b>	<b>G</b>	Inlet 1/2" a	46	46	49
<b>ISO 7-1/BS 21</b>	<b>Rc</b>				
<b>ASME B1.20.1</b>	<b>NPT</b>	Inlet 3/4", 1" a	56	56	59
		Outlet b	30	37	37
<b>Height [mm]</b>					
		Inlet 1/2" H max.	209	209	212
		Inlet 3/4", 1" H max.	219	219	222

### Inlet thread "Male"

Size outlet body		1/2"	3/4"	1"	
<b>Center to face [mm]</b>					
<b>DIN ISO 228-1</b>	<b>G</b>	Inlet a	33	33	36
		Outlet b	30	37	37
<b>ISO 7-1/BS 21</b>	<b>R</b>	Inlet a	31	31	34
<b>ASME B1.20.1</b>	<b>NPT</b>	Outlet b	30	37	37

### Height [mm]

		Size inlet thread	3/8"	1/2"	3/4"	1"
<b>DIN ISO 228-1</b>	<b>G</b>	H max.	208	210	212	217
<b>ISO 7-1/BS 21</b>	<b>R</b>	H max.	–	213	214	220
<b>ASME B1.20.1</b>	<b>NPT</b>	H max.	–	216	216	224

### Length of screwed end "c" [mm]

		Size inlet thread	3/8"	1/2"	3/4"	1"
<b>DIN ISO 228-1</b>	<b>G</b>		12	14	16	18
<b>ISO 7-1/BS 21</b>	<b>R</b>		–	19	20	23
<b>ASME B1.20.1</b>	<b>NPT</b>		–	22	22	27

Available threaded connections refer to page 04/04.

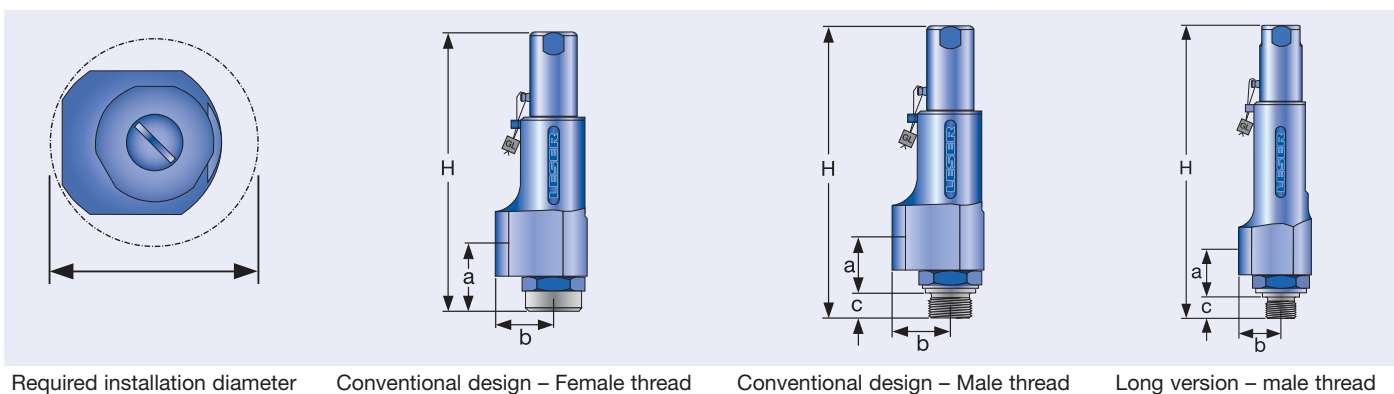

Required installation diameter

Conventional design – Female thread

Conventional design – Male thread

Long version – male thread

## Dimensions and weights – Metric Units

### Flanged connection

Actual Orifice diameter $d_0$ [mm]	10
Actual Orifice area $A_0$ [mm <sup>2</sup> ]	78.5

#### DIN EN 1092-1 (Available flange sizes refer to page 04/05)

			Flange rating PN 40
Center to face	[mm]	Inlet a	100
		Outlet b	100
Height	[mm]	H max.	263

			Flange rating $\geq$ PN 160
Center to face	[mm]	Inlet a	103
		Outlet b	100
Height	[mm]	H max.	266

#### ASME B 16.5 (Available flange sizes refer to page 04/05)

			Flange rating class 150
Center to face	[mm]	Inlet a	100
		Outlet b	100
Height	[mm]	H max.	263

			Flange rating class $\geq$ 300
Center to face	[mm]	Inlet a	103
		Outlet b	100
Height	[mm]	H max.	266

**Note** The outlet dimension b can differ at special combinations of nominal diameter and pressure range if flanged connections are used at the inlet and outlet. Special dimensions are possible. More information at sales@leser.com.

### Weight

To calculate the total weight use the formula:  $m_T = m_N + m_F$  (Inlet) +  $m_F$  (Outlet)

<b>Weight net</b> [kg]	$m_N$	2.4
(without inlet and outlet flange)		

### Flange dimensions

	Size	DIN EN 1092-1 / Flange rating PN						ASME B16.5 / Flange rating					
		40	100	160	250	320	400	150	300	600	900	1500	2500
<b>DN 15</b>		<b>NPS 1/2"</b>											
Flange thickness [mm]	s	18	–	22	28	28	30	14	18	18	26	26	30.2
Weight slip on flange [kg]	$m_F$	0.8	–	1.2	2.5	2.5	3.6	0.6	0.9	0.9	2.1	2.1	3
<b>DN 20</b>		<b>NPS 3/4"</b>											
Flange thickness [mm]	s	20	22	–	–	–	–	15	18	18	25.4	25.4	32
Weight slip on flange [kg]	$m_F$	1.1	1.3	–	–	–	–	0.8	1.4	1.4	2.3	2.3	3.5
<b>DN 25</b>		<b>NPS 1"</b>											
Flange thickness [mm]	s	22	–	26	30	36	40	17	21.5	21.5	32.5	32.5	40
Weight slip on flange [kg]	$m_F$	1.3	–	2.6	3.5	5	7.5	1	2.1	2.1	4.1	4.1	5.1

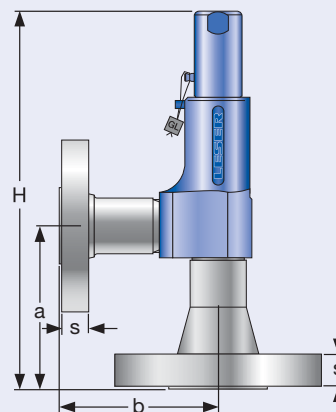

Conventional design

## Available Options

<p><b>Male thread</b></p>	<p><b>Female thread</b></p>	<p><b>Flanged version</b></p>	
<p><b>Vulcanized soft seal disc</b>          J30: NBR "N"          J21: CR "K"          J22: EPDM "D"          J23: FKM "L"          J20: FFKM "C"</p>			
<p><b>Heating jacket</b>          H29</p>	<p><b>Test gag</b>          J70: H2</p>	<p><b>INCONEL X-750 spring</b>          X08</p>	
<p><b>Special material</b>          2.4610 Hastelloy® C4          2.4360 Monel® 400          1.4462 Duplex</p>			

Type 439



## Available connections

For dimensions and weights refer to:

Type 437 – page 01/08 + 01/10

Type 438 – page 02/08 + 02/10

Type 439 – page 03/08 + 03/10

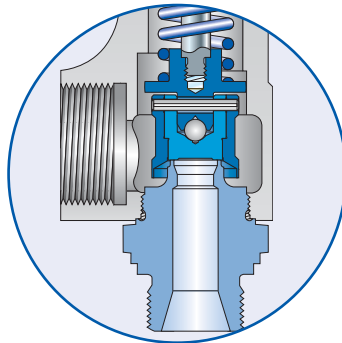

Male thread

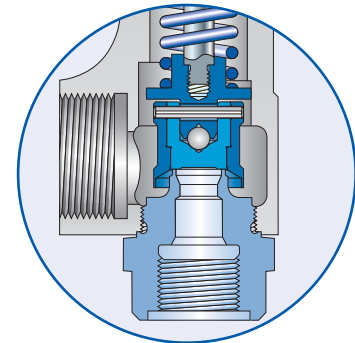

Female thread

### Threaded connections

	Valve size	d <sub>0</sub> 6 mm		d <sub>0</sub> 10 mm	
		Inlet	Outlet	Inlet	Outlet
		Option code	Option code	Option code	Option code
<b>Male thread DIN ISO 228-1</b>					
<b>G</b>	3/8"	V49	–	V49	–
	1/2"	V54	–	V54	–
	3/4"	V55	–	V55	–
	1"	V56	–	V56	–
<b>Female thread DIN ISO 228-1</b>					
<b>G</b>	1/2"	V50	V65	V50	V65
	3/4"	V51	V76	V51	V76
	1"	V52	V66	V52	V66
<b>Male thread DIN ISO 7- 1 / BS 21</b>					
<b>R/BSPT</b>	1/2"	V30	–	V30	–
	3/4"	V31	–	V31	–
	1"	V32	–	V32	–
<b>Female thread DIN ISO 7- 1 / BS 21</b>					
<b>Rc/BSPT</b>	1/2"	V38	V34	V38	V34
	3/4"	V39	V35	V39	V35
	1"	V40	V36	V40	V36
<b>Male thread ANSI / ASME B1.20.1</b>					
<b>NPT</b>	1/2"	V61	–	V61	–
	3/4"	V62	–	V62	–
	1"	V63	–	V63	–
<b>Female thread ANSI / ASME B1.20.1</b>					
<b>NPT</b>	1/2"	V58	V70	V58	V70
	3/4"	V59	V77	V59	V77
	1"	V60	V71	V60	V71

Flanged and threaded connections can be combined.

Threads according to other standards are available.

Please specify in writing (diameter, pressure rating, standard).

## Available connections

For dimensions and weights refer to:  
 Type 437 – page 01/09 + 01/11  
 Type 438 – page 02/09 + 02/11  
 Type 439 – page 03/09 + 03/11

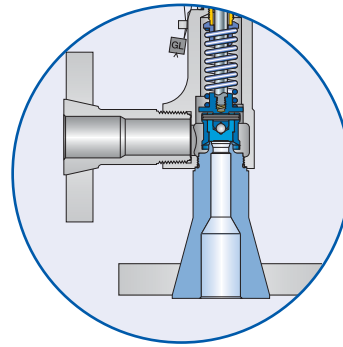

Flanged version

Flanged connections					
Valve size	Pressure rating	d <sub>0</sub> 6 mm		d <sub>0</sub> 10 mm	
DIN EN 1092-1 (PN > 100: DIN 2501)					
DN	PN	Option code		Option code	
		Inlet	Outlet	Inlet	Outlet
15	40		I40	I21	I40
	160		I41	I22	I41
	250	I23	I42	I23	I42
	320	I24	–	I24	–
	400	I25	–	I25	–
20	40	I26	I43	I26	I43
	100	I27	I44	I27	I44
25	40		I46	I31	I46
	160		I47	I32	I47
	250	I33	I48	I33	I48
	320	I34	–	I34	–
	400	I35	–	I35	–
ANSI/ASME B16.5					
NPS	CL	Option code		Option code	
		Inlet	Outlet	Inlet	Outlet
1/2"	150		V24	V01	V24
	300		V13	V02	V13
	600		V13	V02	V13
	900	V03	V14	V03	V14
	1500	V03	–	V03	–
	2500	V04	–	V04	–
3/4"	150		V15	V05	V15
	300		V16	V06	V16
	600		V16	V06	V16
	900	V07	V17	V07	V17
	1500	V07	–	V07	–
	2500	V08	–	V08	–
1"	150		V18	V09	V18
	300		V19	V10	V19
	600		V19	V10	V19
	900	V11	V20	V11	V20
	1500	V11	–	V11	–
	2500	V12	–	V12	–

Flanged and threaded connections can be combined.  
 Threads according to other standards are available.  
 Please specify in writing (diameter, pressure rating, standard).